

**CPM  
HYGIENISER**



**CALIFORNIA  
PELLET MILL**

*Your Partner in Productivity*



**HEAT TREATMENT  
FOR HYGIENIC FEED**

# CPM HYGIENISER

## DIMENSIONS AND CAPACITIES

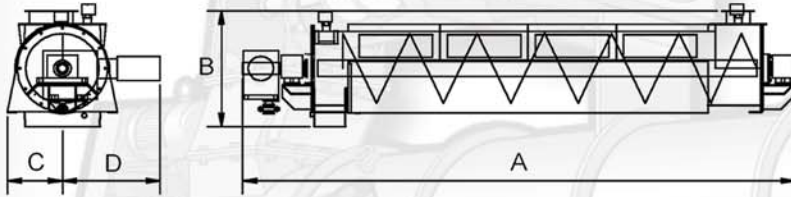

MODEL	A	B	C	D
24LLJ12ST	180" (4520mm)	39" (995mm)	18" (450mm)	32" (800mm)
36LLJ13ST	195" (4950mm)	54" (1375mm)	27" (675mm)	32" (800mm)
48LLJ13ST	246" (6110mm)	61" (1552mm)	30" (754mm)	N/A
48LLJ16ST	276" (7021mm)	61" (1552mm)	30" (754mm)	N/A

\* Dimensions and specifications are approximate and subject to change.

### PRESS FEEDER

- Variable speed
- Uniform flow of meal into pellet mill
- Low profile design
- 3.0 HP(2.2KW) gear drive



MODEL	CAPACITY TPH				
	MINUTES				
	2	3	4	5	6
24LLJ12ST	15.0	10.0	7.5	6.0	5.0
36LLJ13ST	30.0	20.0	15.0	12.0	10.0
48LLJ13ST	60.0	40.0	30.0	25.0	20.0
48LLJ16ST	80.0	50.0	40.0	30.0	25.0

\*\*Based on 80% fill rate and 40 lbs/ft3 product density.

## FEATURES

- Salmonella control
- First in first out (FIFO)
- Longer retention times
- Self cleaning – no buildup
- Improved pellet quality
- Low energy consumption
- Installs in existing locations
- Increased die and roll life
- Excellent conditioning
- Flexible temperature and retention times
- Steam jacketed
- Insulated barrel

## MANY APPLICATIONS

- Poultry feed
- Pig feed
- Fish meal
- Ruminant feed

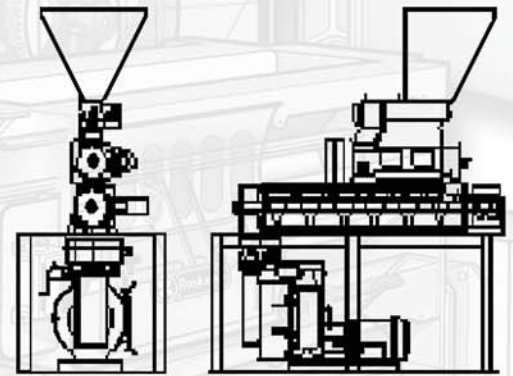

## TECHNICAL SPECIFICATIONS

MODEL	INTERNAL DIAMETER	DRIVE CAPACITY HP (KW)	SHAFT SPEED (rpm)	STEAM-JACKET PRESSURE MAX PSI (Bar)	STEAM JACKET USE Lb/h (Kg/h)	WEIGHT LBS (Kg)
24LLJ12ST	24" (630mm)	3.0 (2.2)	0-6	100 (6.9)	440 (200)	3960 (1800)
36LLJ13ST	36" (930mm)	4.0 (3.0)	0-6	100 (6.9)	660 (300)	5940 (2700)
48LLJ13ST	48" (1220mm)	5.0 (3.8)	0-6	100 (6.9)	950 (430)	8800 (4000)
48LLJ16ST	48" (1220mm)	5.0 (3.8)	0-6	100 (6.9)	1200 (545)	9680 (4400)

\* Dimensions and specifications are approximate and subject to change.



**CPM: A World Wide Company with Local Representatives for Sales, Service and Support**

**California Pellet Mill**  
1114 E. Wabash Ave.  
Crawfordsville, IN 47933  
(800) 428-0846

**Roskamp Champion**  
2975 Airline Circle  
Waterloo, IA 50703  
(800) 366-2563

**Beta Raven**  
40 S. Corporate Hills,  
Ste. 102  
St. Charles, MO 63301  
(800) 552-2382

**Century Extrusion**  
2412 Aero Park Court  
Traverse City, MI 49686  
(231) 947-6400

**Wolverine Proctor**  
251 Gibraltar Road  
Horsham, PA 19044  
(215) 443-5200

**Crown Iron Works**  
2500 West County Road C  
Roseville, MN 55113  
(651) 639-8900